



ICE FLAKER

ICM32-120



INDEX

1. Features	2
2. Notes Before Operation	2
3. Structure	3
4. Operation Procedures	4
5. Maintenance	5
6. Technical Parameters	5
7. Troubleshooting	6
8. Circuit Diagram	7

1. Features

Our Ice Flaker Series are designed in cubic shape with the curved front panel and curved door (or stainless steel flat front panel and flat door) for nice appearance. There are many advantages of the ice maker, such as quick ice making, great ice making capacity, nice ice shape and ice dropping quickly. Tap water inlet > water incoming > ice making > crush ice > ice dropping > ice storing, all these processes are automatically controlled for ice making continuously. In case of water shortage or ice full in the cabinet, the indicator on the operation board will light on accordingly and the ice maker will stop operation automatically. The ice storage cabinet is PU foamed, so it is insulated well and it could prevent the ice made from melting. Also, the remaining water after ice made each time is used for recycling. So not only the water is saved, but also the ice making efficiency is enhanced and the energy consumption is reduced, and the customer's ice making cost is also reduced much. Either purified water or the tap water could be used for ice making.

2. Notes Before Operation

1. The incline angle of the cabinet could not be over 45° during transportation. Don't make ice maker upside-down in case the compressor or refrigerating system troubles occur.
2. The flake ice maker should be placed on horizontal and structurally sound ground and away from heat source and corrosive gas. At least about 150mm space should be left around the ice maker to ensure the fine ventilation.
3. Before using the flake ice maker for the first time, you should wait 12 hours after positioning it in a proper place.
4. Voltage range: 187 ~242V(220V) and 100—130V(110V)
5. The rated capacity of wire should be over 6A, the section area of the wire is 0.75mm². The wire could be consisted by single ply or multiplies. The rated current of fuse is 5A.
6. The separate three-pole outlet should be used and the grounding must be good.
7. If the supply cord is damaged, it must be replaced by the manufacturer, its service agent or similarly qualified persons in order to avoid a hazard.
8. This appliance is not intended for use by children or other persons without assistance or supervision if their physical, sensory or mental capabilities prevent them from using it safely. Children should be supervised to ensure that they do not play with the appliance.

3. Structure

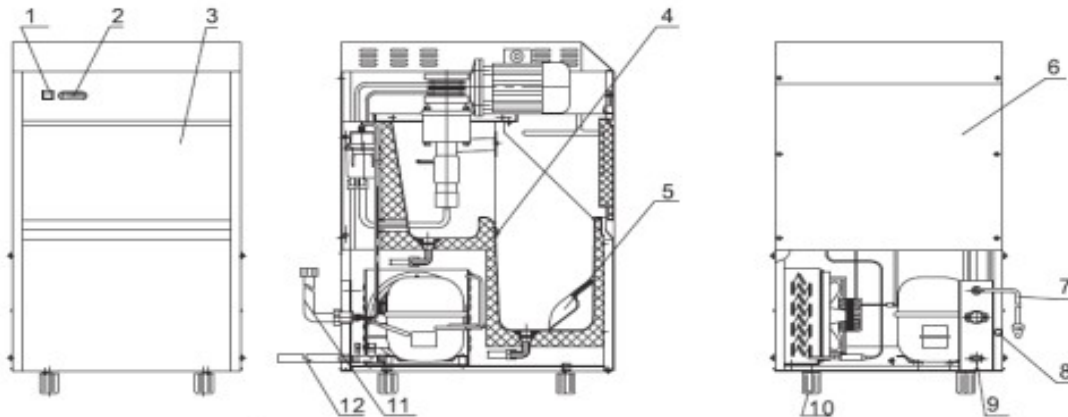

1. Switch	5. Ice Shovel	9. Water Outlet Tube
2. Operation Board	6. Back Panel	10. Foot Screw
3. Door	7. Power Cable	11. Water Inlet Tube
4. Temperature Sensor	8. Screw for Drainage	12. Drainage Tube

4. Operation Procedures

1. Unpack the package and take out the attached documents and spare parts such as the water inlet and outlet tubes, ice shovel and gaskets, etc.
2. Position the ice maker on a well ventilated place and leave at least 150mm space between the ice maker and the wall. Be sure the ice maker is positioned levelly and away from the heat source.
3. Make one end of the $\Phi 12$ flexible plastic corrugated pipe (supplied with the maker) connected with the water outlet tube on back of the maker, another pipe end should be placed in a container for surplus water (prepared by user himself) or in the sewer.
4. Make one end of the water inlet tube (supplied with the maker) connected with the 3/4" screw type connector of the water tap so as to get the drinkable tap water. The water pressure of water supply pipe is 1.5 ~ 3 bar.
The other end of the water inlet tube should be connected with the screw type connector of water valve on the back of the ice maker. Be sure to put gaskets (supplied with the maker) in both ends of the water inlet tube before connecting.
If it is an ice maker for purified water, a $\Phi 12$ corrugated pipe (supplied with the maker) should be used. Connect one end of the pipe with the purified water supplier (desk-top water dispenser) and another end with a water valve connector on the back of the ice maker. The desk-top water dispenser should be placed on the ice maker at the back position.
5. Make proper connection and press on the start button on the operation board for about 4 seconds till the run indicator and the big ice indicator (or small ice indicator) light on. Then the maker begins to work. All the procedures, water inlet > ice making > crush ice > ice dropping > ice storing, are controlled automatically for ice making continuously.

If ice is full in the ice storage container, the ice full indicator on the operation board will light on and ice maker will stop automatically. If there is a water shortage or something wrong with the water supply system, the Water shortage indicator will light on and the ice maker will stop operation automatically.

5. Maintenance

1. If the compressor stops for any reasons like water shortage, too much ice, power off, etc., don't restart it right away. You can restart it about 5 minutes later.
2. Check regularly the connectors of the water inlet and outlet tubes and drain the little surplus water that may leak.
3. If the ice maker will be unused for a long period, please off the plastic drainage connector screw on the back of the ice maker so as to drain the surplus water in the water groove. Then screw it on. Wipe the inner liner of the ice storage container with a clean rag.
4. When plugging or unplugging, the plug should be held by hand and the wires should not be dragged heavily.

6. Technical Parameters

Capacity	120 kg/24 h
Storage Bin Capacity	40 kg
Refrigerant	R134a
Condenser Type	Air cooled
Overall Dimension	500x611x940 mm
Packing Dimension	570x685x1000 mm
Weight	58/63 kg
Power	550 W
Power Supply	220 V, 60 Hz

The specifications are subject to be changed without notice. Please check the nameplate for sure.

7. Troubleshooting

(FOR REFERENCE OF USERS AND TECHNICIANS)

TROUBLE	CAUSE	REMEDY
The Ice Flaker does not work.	<ol style="list-style-type: none"> 1. The voltage is lower than the lower limitation 2. The ambient temperature is too low (Lower than 10 °C) 	<ol style="list-style-type: none"> 1. Stop the ice maker and restart it until the voltage is normal. 2. Try again when the ambient temperature higher than 10 ° C
Water shortage indicator light on.	<ol style="list-style-type: none"> 1. Water shortage from the water supply system. 2. Water valve damage. 3. Tap water pressure too low 	<ol style="list-style-type: none"> 1. Check the water supply. If it is OK, restart the maker. 2. Check the water valve. 3. Be sure the tap water pressure is higher than 1.5 bar.
Compressor does not work	<ol style="list-style-type: none"> 1. Water shortage. 2. Ice full. 	<ol style="list-style-type: none"> 1. Check the water supply system (water valve and water supply tube). 2. Take off some ice.
Compressor works, but no ice is made.	<ol style="list-style-type: none"> 1. Refrigerant leakage. 2. The refrigerating system is blocked. 	<ol style="list-style-type: none"> 1. Recharge the refrigerant and check the leakage again. 2. Charging N2 to check whether the system is blocked and replace the filler. 3. Check whether fan is running.
Water shortage indicator and ice full indicator are glittering at the same time.	If water inlet jam or running failure because of low environmental temperature.	Stop the machine until the temperature reaches IOU or repair it by authorized service people.

8. Circuit Diagram

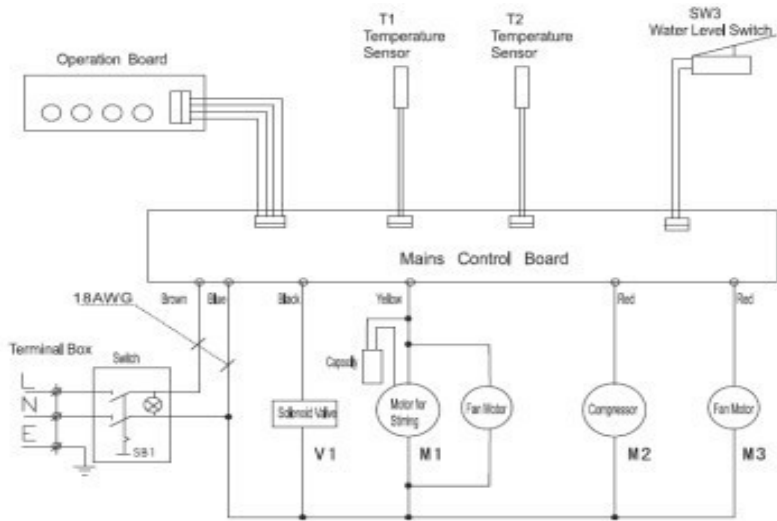

LABSTAC

Labstac LLC

82 Wendell Avenue, STE 100, Pittsfield, MA, 01201, USA

Email: contact@labstac.com | Website: labstac.com